

**FORD TRANSIT CUSTOM****2.0L TURBO DIESEL ECOBLUE EURO 6**

250 / 270 / 290 / 310 / 340

CODE / CODICE: 0500.8402**COMPRESSOR / COMPRESSEUR / KOMPRES-
SOR / COMPRESSORE / COMPRESOR :****SELTEC TM13 / 15 / 16****QUE QP13 / 15 / 16**

FITTING INSTRUCTIONS**EINBAUANLEITUNGEN****INSTRUCTIONS POUR LE MONTAGE****ISTRUZIONI DI MONTAGGIO****INSTRUCCIONES DE MONTAJE**

Contents

ENGLISH	4
Parts View.....	4
Parts List	5
Compressor Configurations	6
Standard Fastener Torque Values	6
Kit Details	7
Vehicle Details	7
Forward	7
Pre Installation.....	8
Installation	8
Idle pulley Mount.....	9
Crankshaft pulley	10
Intake Pipe	12
Mount brackets.....	12
Compressor Installation.....	14
Drive belt	14
Pulley cover	14
Washer bottle filler	14

PARTS VIEW / VUE ÉCLATÉE / TEILEANSICHT / VISTA PARTA / IMÁGENES DE LAS PIEZAS

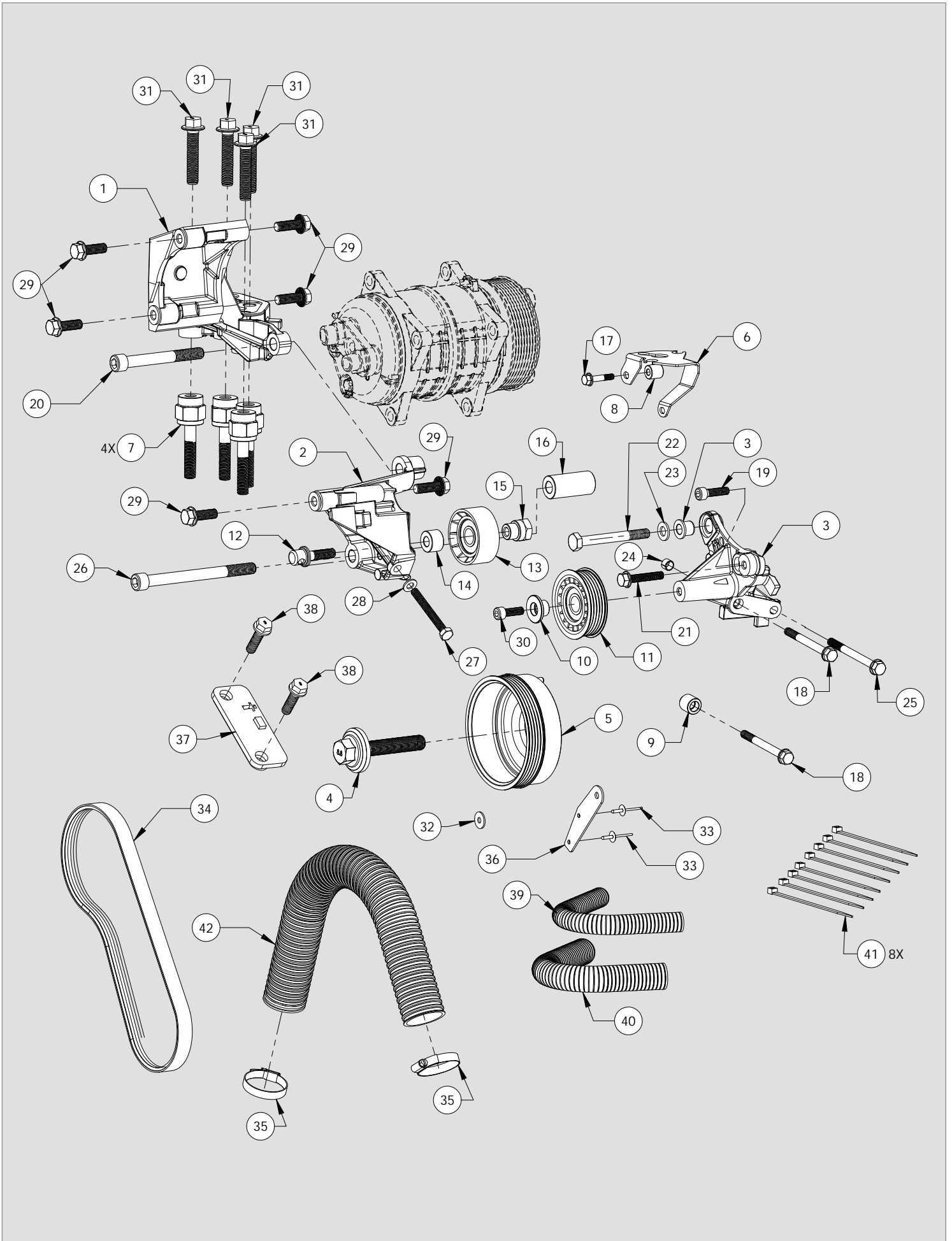

PARTS LIST / NOMENCLATURE / TEILELISTE / ELENCO DELLE PARTI / LISTA DE PIEZAS

ITEM	CODE / CODICE / KODE / CODIGO	DESCRIPTION / DESCRIZIONE / BESCHREIBUNG / DESCRIPCION	QTY.	COMMENTS
1	0441.5641	CMB Assy Ford Panther 2.0I FWD inc AC	1	
2	0441.5651	Tensioner Bracket Assy Ford Panther 2.0I FWD inc AC	1	
3	0441.5661	Pulley Mount Bracket Assy Ford Panther 2.0I FWD inc AC	1	
4	2711.0071	Hexagon flange bolt inc washer M16 x 90 : 1.5 - 8.8	1	
5	1701.5522	Crank Pulley Assy Ford Panther 2.0L	1	
6	3020.7011	Heater Pump Mount Panther 2.0L	1	
7	2803.6441	M12 Threaded Pillar 28mm AF	4	
8	2803.6451	Spacer OD 15 x ID 6.6 x L 15	1	
9	2803.6461	Alignment Spacer OD 18 x ID 9 x L 16	1	
10	2803.6471	C-Bored - Spacer ID 8.3 OD 16.8 L 14.5	1	
11	1700.5221	5PK Idle Pulley	1	
12	1703.0153	Eye Bolt - 37 X M10 : 1.50 - 9 GL	1	
13	1700.0341	Idle Pulley 60.2 x 25.5	1	
14	2803.6481	Spacer OD 23 x ID 10.5 x L 15	1	
15	1710.0071	Idle Pulley Nut - M10 x 1.5 - 6H	1	
16	2803.6491	Spacer -OD 25 x ID 12.5 x L52	1	
17	2702.0511	Hexagon flange bolt M6 X 30 : 1.00	1	
18	2704.5801	Hexagon flange bolt - M8 x 80 : 1.25 - 8.8	2	
19	2704.5551	Hexagon socket head cap screw M8 x 30 : 1.25 - 12.9	1	
20	2706.5211	Hexagon socket head cap screw M12 x 100 : 1.75 - 12.9	1	
21	2704.0161	Hexagon flange bolt Durluk - M8 x 45 : 1.25 - 12.9	1	
22	2705.5441	Hexagon Head Bolt - M10 x 90 ~ 1.5 : 10.9	1	
23	2809.0011	Washer M10 Flat DIN 125 - A 10.5	1	
24	2800.5533	Split Dowel Bush - OD11.04 ID8.85 L8	1	
25	2704.5381	Hexagon flange bolt - M8 x 90 : 1.25 - 8.8	1	
26	2706.5221	Hexagon socket head cap screw M12 x 140 : 1.75 - 12.9	1	
27	2719.0301	Hex Set Screw - M8 x 70 : 1.25 - 8.8	1	
28	2808.0011	Washer M8 Flat DIN 125 - A 8.4	1	
29	2705.0491	Hexagon flange bolt Durluk - M10 x 30 : 1.50 - 12.9	6	
30	2704.5371	Hexagon socket head cap screw M8 x 25 : 1.25 - 12.9	1	
31	2706.5071	Hex flange bolt - M12 x 60: 1.75 - 10.9	4	
32	2806.0501	M6 x 18 x 1.6 - DIN 9021 A2	1	
33	2760.1031	Rivet 4.0 x 12.0	2	
34	0820.7951	Belt - Poly Groove 5PK 1413ES	1	
35	1537.1091	Hose clamp ~ Double Wire 41-46	2	
36	3020.7031	Pulley Guard Support Plate	1	
37	2510.5151	Flywheel Locking Tool Ford Panther 2.0I	1	
38	2705.5301	Hexagon flange bolt - M10 x 35 : 1.50 - 8.8	2	
39	1430.0081	Split tube 300mm 20 OD	1	
40	1430.0231	Split tube 300mm 28 OD	1	
41	2763.0051	Cable Tie 4.8 x 370 - Black	8	
42	1420.0042	40 ID 450mm long	1	

**COMPATIBLE COMPRESSORS / COMPRESSEURS RECOMMANDÉS / EMPFOHLENE KOMPRESSOREN
RACCOMANDATO COMPRESSORI / RECOMENDADAS COMPRESORES**

SELTEC	TM-13 HS	TM15-HS	TM16-HS
Comp No	0381.0352	0381.5002	0381.0372
Valeo No.	488-44122	488-45122	488-46122
Mounting	Ear	Ear	Ear
Rotor	8PV	8PV	8PV
GL	46.55	46.55	46.55
Armature	3E	3E	3E
Diameter	123	123	123
Voltage	12	12	12
Orientation	H	H	H
Fitting	3/4 x 7/8	3/4 x 7/8	3/4 x 7/8
Manifold	Bolt	Bolt	Bolt

QUE	QP13-HD	QP15-HD	QP16-HD
Comp No	0391.0352	0391.5002	0391.0372
Que No.	QP13-1274	QP15-1548	QP16-1197
Mounting	Ear	Ear	Ear
Rotor	8PV	8PV	8PV
GL	46.55	46.55	46.55
Armature	3E	3E	3E
Diameter	123	123	123
Voltage	12	12	12
Orientation	H	H	H
Fitting	3/4 x 7/8	3/4 x 7/8	3/4 x 7/8
Manifold	Bolt	Bolt	Bolt

SANDEN	-	-	-
Comp No	-	-	-
Sanden No.	-	-	-
Mounting	-	-	-
Rotor	-	-	-
GL	-	-	-
Armature	-	-	-
Diameter	-	-	-
Voltage	-	-	-
Orientation	-	-	-
Fitting	-	-	-

NOTES

STANDARD FASTENER TORQUE VALUES

In the absence of specific torque values detailed in this fitting instruction manual, the following chart can be used as a guide to the maximum safe torque for specific size and grade of fastener.

COUPLES DE SERRAGE DES FIXATIONS STANDARDS

Si des chiffres de serrage au couple particuliers ne sont pas indiqués dans cette notice de montage, se référer au tableau suivant qui servira de guide pour le couple de sécurité maximum correspondant à une taille et un grade spécifiques de fixation.

ANZIEHMOMENTE FÜR STANDARDBEFESTIGUNGSMITTEL





Falls in dieser Einbauanleitung keine speziellen Anziehmomente angegeben sind, kann die folgende Tabelle als Richtlinie für das maximale sichere Anziehmoment für eine spezifische Größe oder Qualität von Befestigungsmitteln dienen.

VALORI STANDARD DI SERRAGGIO PER DISPOSITIVI DI FISSAGGIO

In assenza di valori specifici di coppia nel presente manuale di istruzioni, si può utilizzare la seguente tabella come guida per conoscere la coppia massima sicura in base a dimensioni e grado del dispositivo di fissaggio.

VALORES ESTÁNDAR DE LOS PARES DE APRIETE Y FIJACIÓN

En ausencia de valores para los pares de apriete específicos detallados en este manual de instrucciones de montaje, se puede utilizar la siguiente tabla como guía para consultar el máximo par de torsión seguro para un tamaño concreto y su grado de fijación.

STRENGTH								
	Max Torque		Max Torque		Max Torque		Max Torque	
Dia / Pitch	lb.ft	Nm	lb.ft	Nm	lb.ft	Nm	lb.ft	Nm
M5 x 0.80	2	3	4.5	6	6.5	9	7.5	10
M6 x 1.00	4	5.5	7.5	10	11	15	13	18
M8 x 1.25	10	13	18	25	26	35	33	45
M10 x 1.25	20	27	39	53	57	78	66	90
M10 x 1.50	18	25	37	50	55	73	63	86
M12 x 1.75	33	45	63	85	97	130	111	150
M14 x 2.00	55	75	103	140	151	205	177	240
M16 x 2.00	85	115	159	215	232	315	273	370

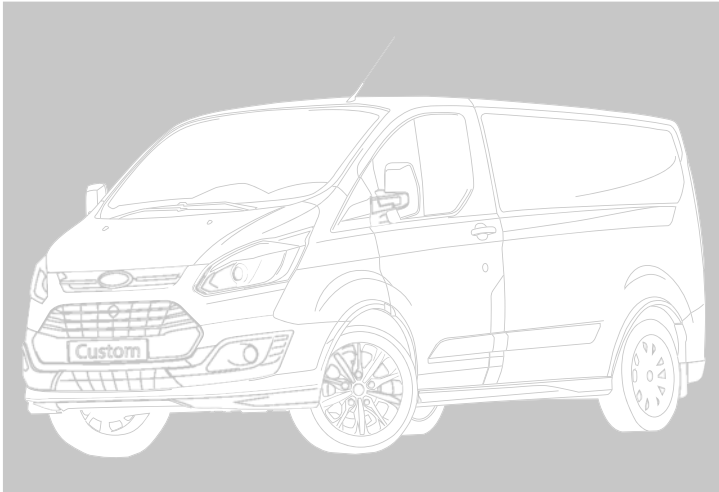

VEHICLE DETAILS

Manufacturer	Ford
Model	Transit Custom
Model Type	250 , 270 , 290 , 310 , 340
Engine	2.0L Turbo Diesel Ecoblue Euro 6
Engine Details	105PS (77kW) / 130PS (96kW) / 170PS (125kW)
Year	06.16>
Chassis Nos.	N/A
LHD	YES
RHD	YES
PAS	YES
A/C	YES
Voltage	12v

KIT DETAILS

Kit Part Number	0500.8402
Description	Standard
Compressor RPM	3700 @ Max engine power output
Fitting Time	120 Minutes
Suction Fitting	90 Degree
Discharge Fitting	90 Degree
Belt Type	5PK 1413ES
Belt Part Number	0820.7951

FOREWORD

The purpose of this manual is to facilitate the installation of a direct drive compressor. The information given is merely instructive, should any complications arise contact the Technical department. The manufacturer's warranty does not cover any problems caused by defective installation or alterations made unless authorised. The manufacturer shall not be responsible for any injury, damage or loss caused directly or indirectly as a result of using this manual or the information contained within it.

1 SAFETY MEASURES:

Before fitting the Compressor adapter drive kit, ensure the following for damage:

- a Inner and outer trim and body work
- b Engine idle pace
- c Check all the vehicle functions

Check list:

- a Ensure that the right kit has been selected
- b Before installing, check that all the correct pieces are present; also ensure that there are no missing or broken pieces
- c When fitting, make sure the vehicle is properly protected against damage.

Installation apparatus

- a Calibrated torque wrench
- b Hand service tools
- c Protective covers and shields

2 PRECAUTIONS

- a Detach the battery negative lead.
- b Torque all bolts where stated using a calibrated torque wrench.
- c Take extreme care with moving parts.
- d Remove the vehicle's ignition key and keep it with you.
- e Wear safeguards and make sure that liquid refrigerant never touches your skin

Caution: Measures must be followed accurately to steer clear of the possibility of damage to individuals

Warning: This calls awareness to actions which must be pursued to avoid damage to the components.

NB: This calls awareness to make the job easier or gives useful information.

PRE- INSTALLATION

N.B Prior to commencing work, please examine the instructions with care. The alphabetical symbols on the diagram relate to written instructions, numerical symbols relate to the parts listing.

INSTALLATION

1. Disconnect battery.
2. Remove O/S headlight (A), and screen-wash filler neck (B). Take care not to damage the filler neck mounting bracket. - Fig 1

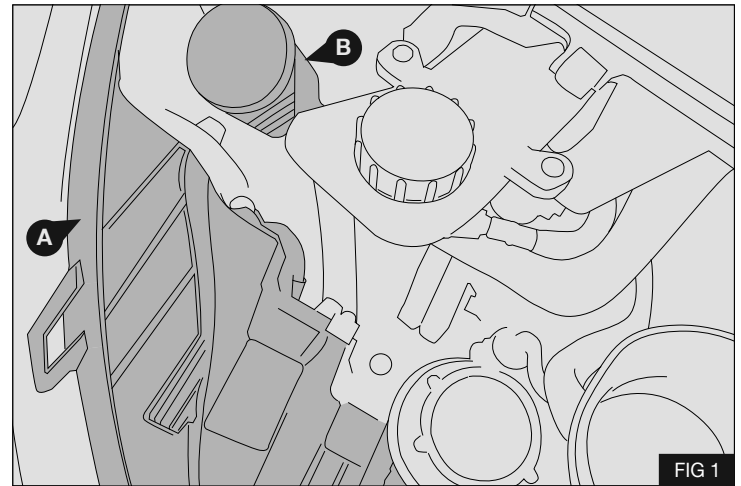

3. Dismount the siren (C). Keep securing nut. - Fig 2

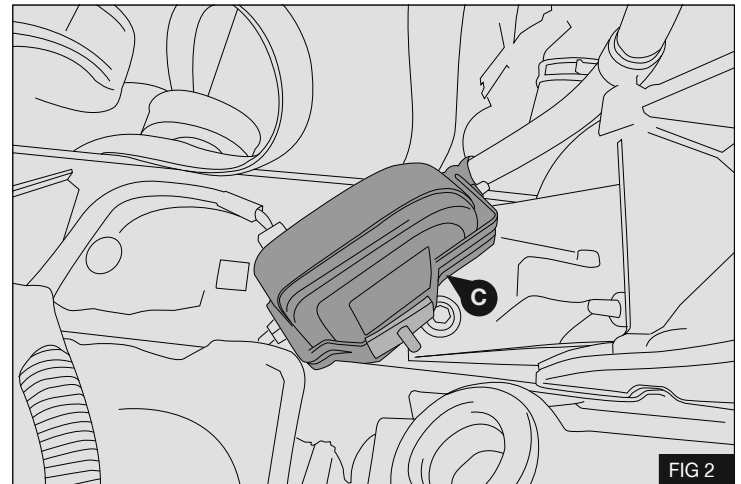

4. Remove the pulley guards (D) and (E). - Fig 3
5. Release the tension on the drive belt (F) lock the tensioner (G) with a suitable Ø4mm pin. Do not remove belt. - Fig 3
6. Remove the Charge duct assembly (H). Protect the openings. - Fig 3

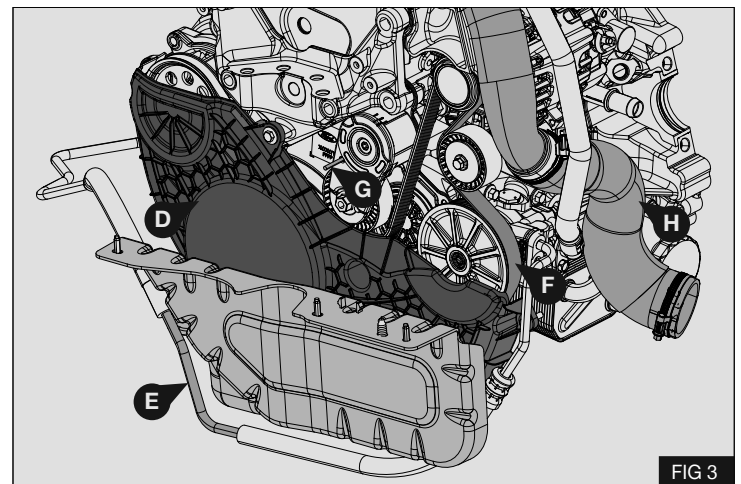

7. Without disconnecting the hoses remove and discard the heater pump mounting bracket (J) retain fasteners (J1) and rubber mounts (J2). - Fig 4

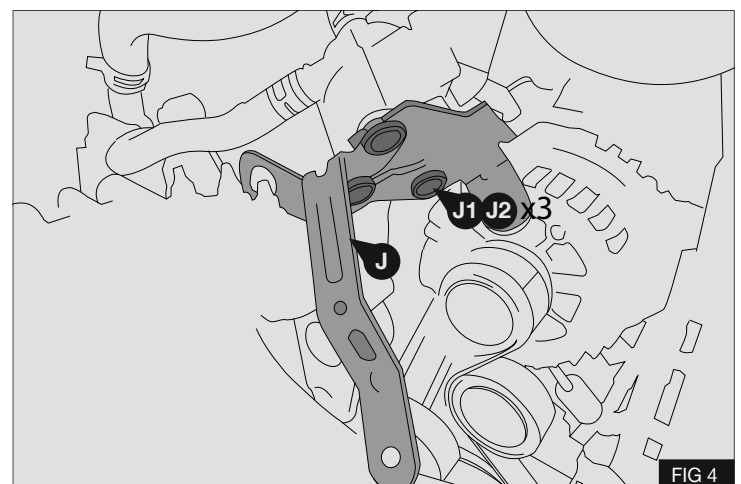

IDLE PULLEY MOUNT

1. Remove the bolts securing the PAS pump (K). (Do not disconnect the hoses). - Fig 5
2. Remove and retain the idle pulley assembly (L).- Fig 5
3. Remove and discard the Alternator lower mounting bolt (M). - Fig 5
4. Slacken the alternator upper mounting bolt (N). - Fig 5

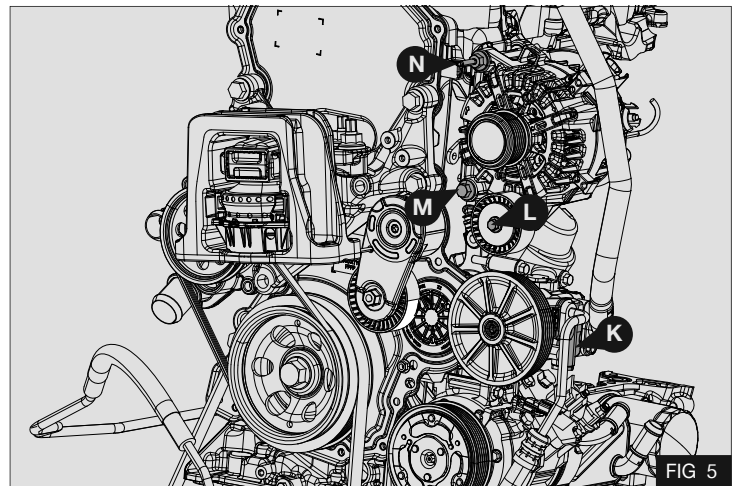

5. Assemble the pulley (11) onto the bracket (3) using spacer (10) and M8 x 25 cap head bolt (30) - Fig 6

Torque bolt (30) to 29Nm

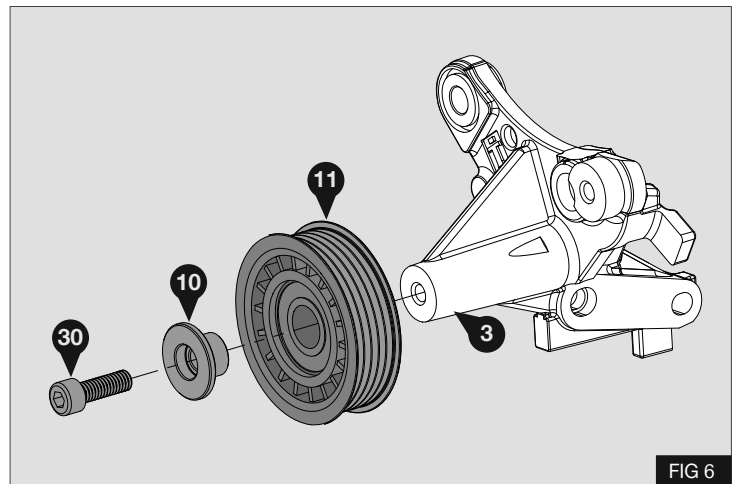

6. Fit lower spacer (9) and insert alignment bush (24).- Fig 7

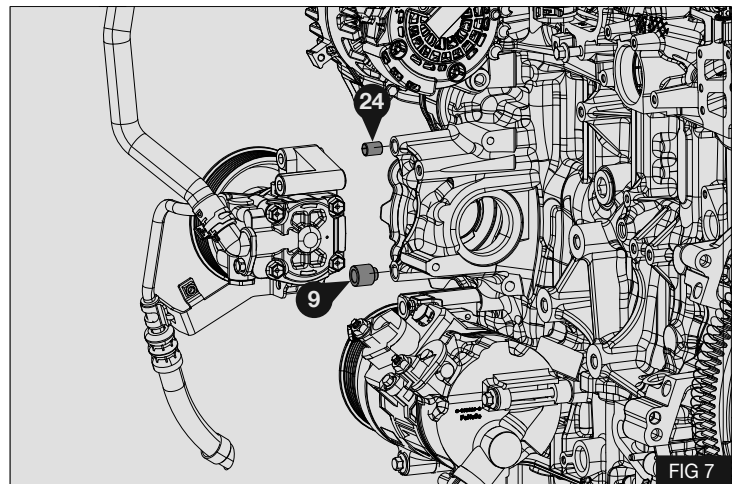

7. Fit the bracket assembly (3) using M10 x90 bolt (22) with washer (23) and M8 x 30 cap head bolt (19). Seat bracket onto alignment bush (24) (previously installed).
8. Do not fully tighten fasteners at this stage. - Fig 8

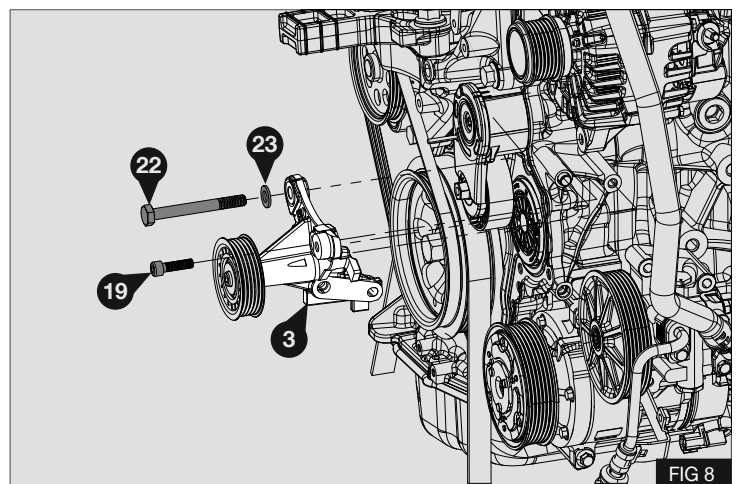

9. Fit the Power steering pump (K) and secure with 2x M8 x 80 bolts (18) and M8x 90 bolt (25). Hand-tighten the bolts until the bracket (3) is fully against the engine block. - Fig 9

Tighten the bolts in the following order:

1. Torque bolt (19) to 29Nm
2. Torque bolts (18), (25) to 25Nm
3. Torque bolt (22) to 45Nm
4. Alternator upper bolt (N) to 45Nm

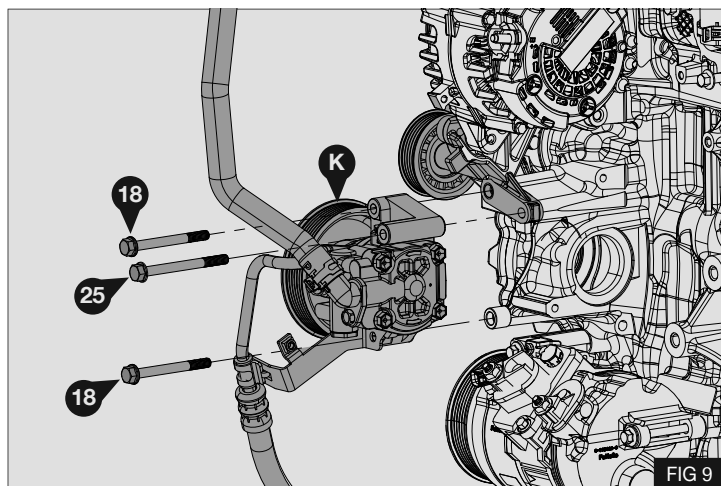

10. Remove and discard the spacer and bolt from the original smooth idler pulley (L)
11. Fit the original smooth idler pulley (L) using M8 x 45 bolt (21). - Fig 10

Torque bolt (21) to 35 Nm

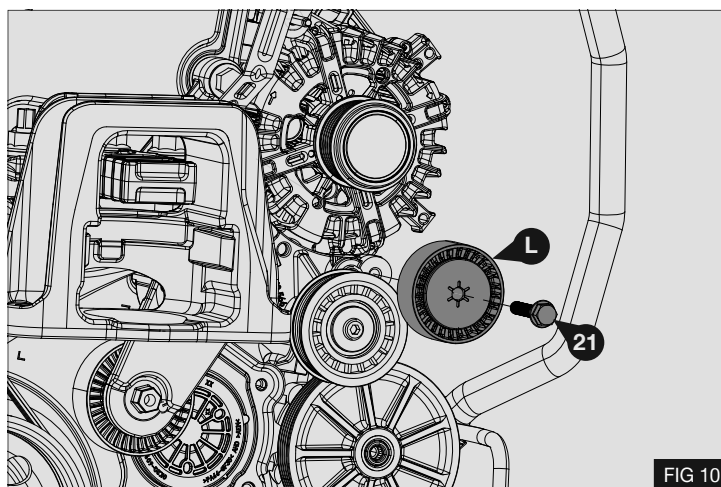

CRANKSHAFT PULLEY

1. Remove and retain the bolts securing the starter motor. Place the starter motor to the side without disconnecting the wiring harness. - Fig 11
2. Fit the crankshaft locking tool (37) using the M10 x 35 bolts (38) - Fig 11

Caution : Discard bolts (38) after use

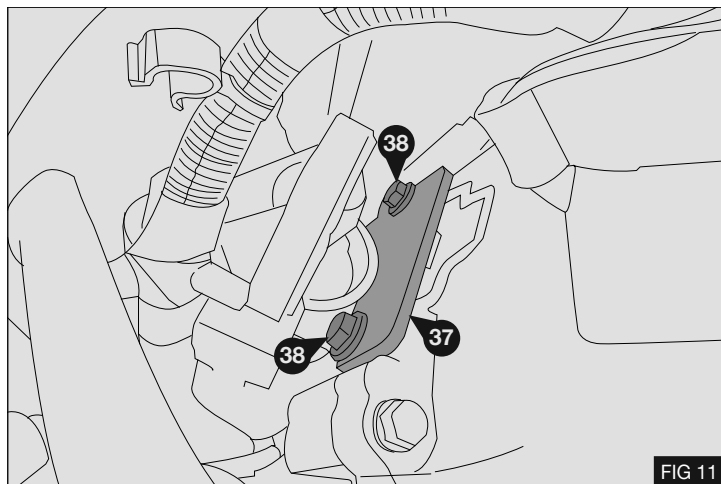

3. Remove and discard the original bolt (S) securing the crank shaft pulley (P) - Fig 12

Note : Do not remove the crankshaft pulley (P)

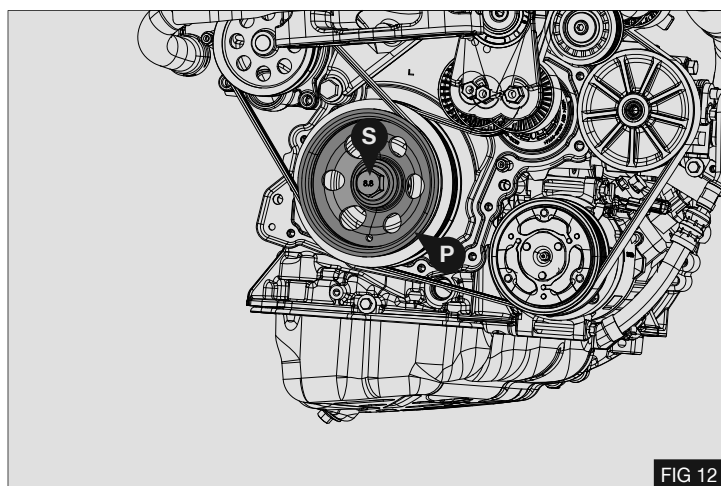

4. Locate the supplied crankshaft pulley (5) on the original pulley (P), Install bolt (4) by hand. - Fig 13

Caution: Ensure the alignment pins in the supplied pulley (5) locate within the M8 threaded holes in the original pulley, and that the pulley (5) is centred in the original pulley (P).

5. Tighten the crankshaft pulley bolt (4) following this procedure exactly.:

CAUTION : DO NOT ATTEMPT TO TIGHTEN THE BOLT USING AN IMPACT WRENCH

1. 10Nm
 2. Loosen:60°
 3. 20Nm
 4. 70Nm
 5. 150Nm
 6. Loosen:90°
 7. 100Nm
 8. 300Nm
 9. Tighten:90°
6. Remove the flywheel locking tool and re-fit the starter motor using the original bolts (Q)
- Torque bolts (Q) to 35Nm
7. Check the original drive belt is located correctly within the pulleys and release the automatic tensioner. - Fig 14

- A Crankshaft Pulley
 B Air conditioning Compressor
 C Power Steering
 D Idle Pulley
 E Alternator
 F Automatic Tensioner

HEATER PUMP

1. Insert the rubber mounts (J2) into the heater pump bracket (6), mount the heater pump (J) re-using fasteners (J1) - Fig 15
2. Fit the heater pump assembly as shown using 1x M6 x 30 (17) and Spacer (8) (remove and discard the current fastener). - Fig 16
3. Torque bolt (17) to 10 Nm

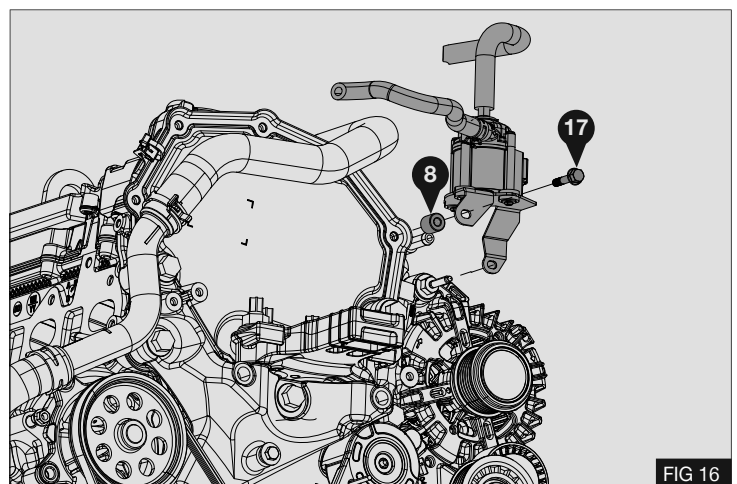
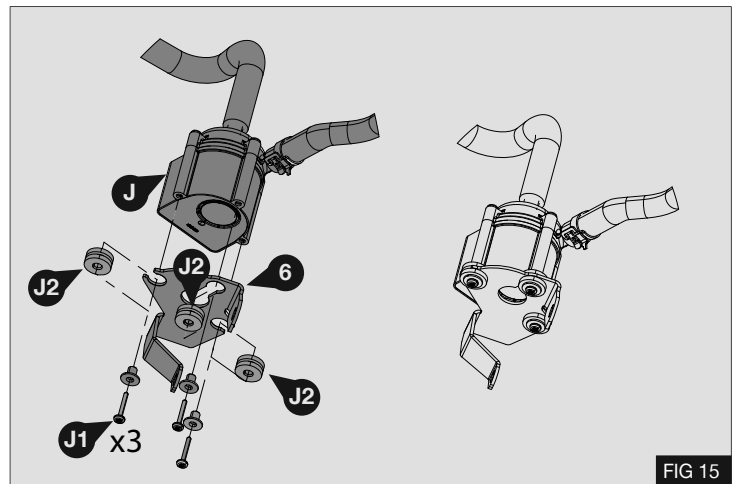
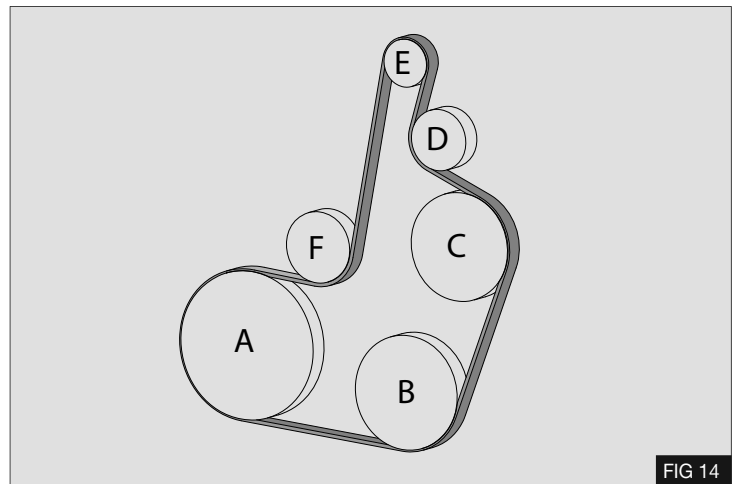
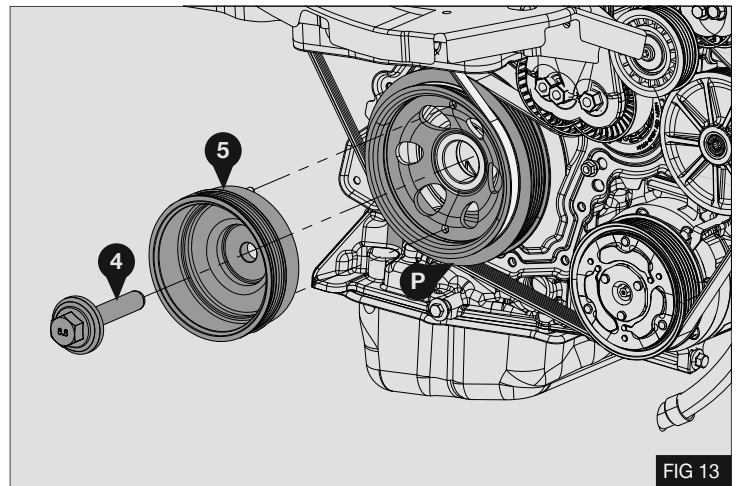

CHARGE DUCT ASSEMBLY

1. Modify the intake pipe (H) by carefully removing the sections shown. - Fig 17
2. Re-fit modified pipe (H) and secure using the original nut and hose clips.

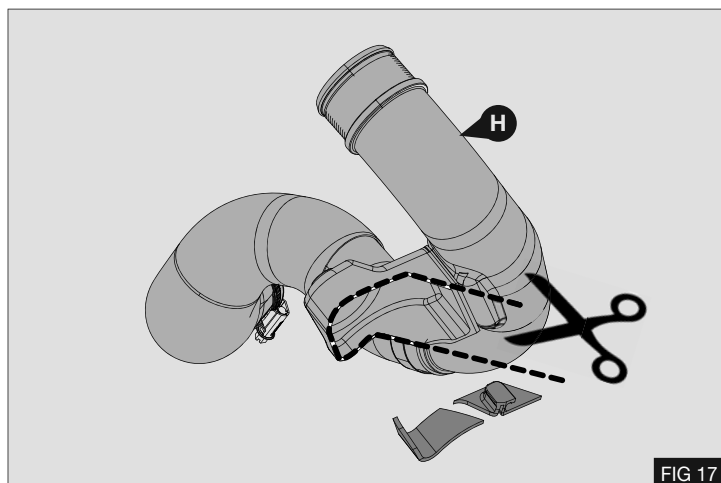

FIG 17

MOUNT BRACKETS

1. Remove and discard 1 x engine mount stud and nut (U) - Fig 18
2. Fit threaded pillar (7)
Torque pillar (7) to 110Nm
3. Repeat previous step for the remaining x3 studs (U) - Fig 19/18

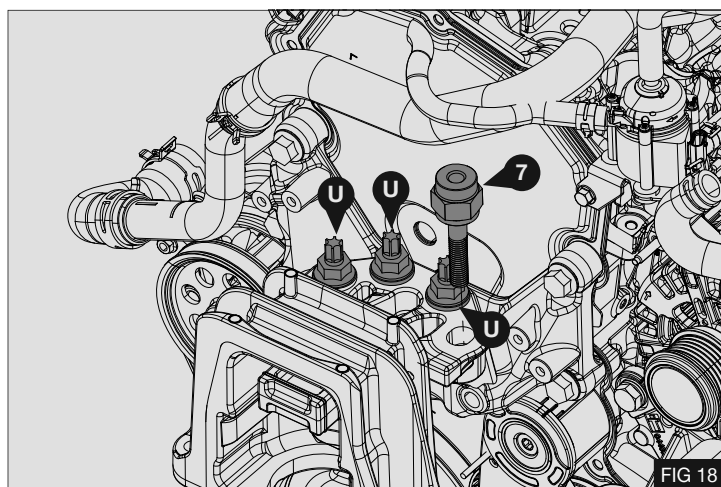

FIG 18

4. Remove and discard engine mount bolts (T) - Fig 19

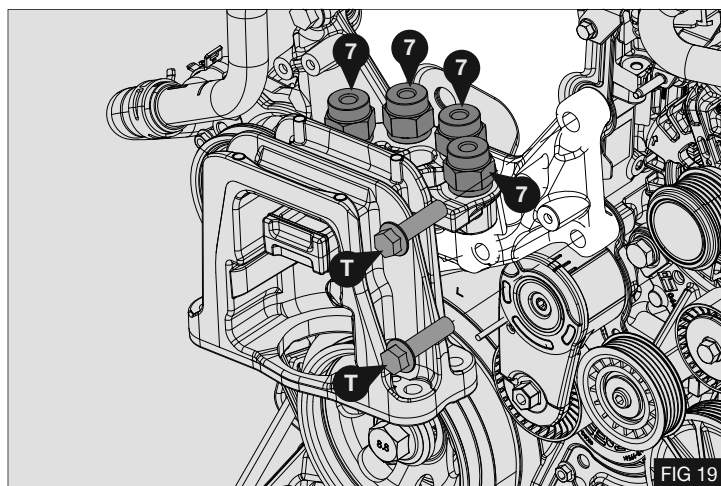

FIG 19

5. Assemble the Idle pulley (13) onto tensioner bracket (2) using Spacer (14) with Eye bolt (12) and pulley nut (15), Insert adjuster bolt (27) with M8 washer (28) - Fig 19

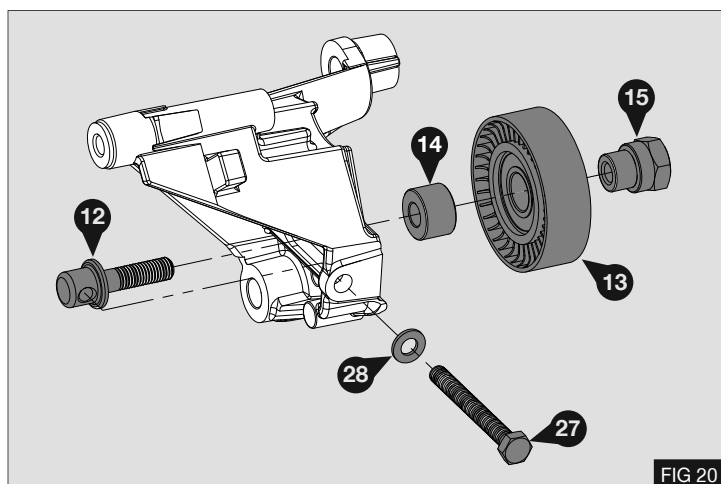

FIG 20

6. Fit adjuster assembly using 1x M12x140 Cap head bolt (26) and spacer (16) as shown, temporarily insert the upper bolt (20) to maintain alignment whilst bolt (26) is tightened. - Figs 21

Torque bolt (26) to 100Nm

Note: It may be necessary to raise the engine to gain better access to tighten this fastener

7. Remove bolt (20)

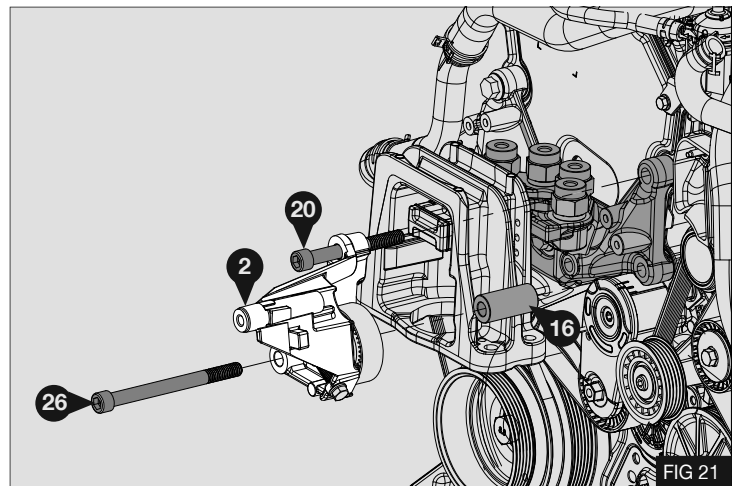

8. Fit the compressor mounting bracket (1) using 4x M12 x 60 flange bolts (31) and 1x M12 x 100 Cap head bolt (20) - Fig 22

9. Hand tighten all bolts, then Torque using following the procedure:

Torque bolt (20) to 120Nm

Torque bolts (31) to 110Nm

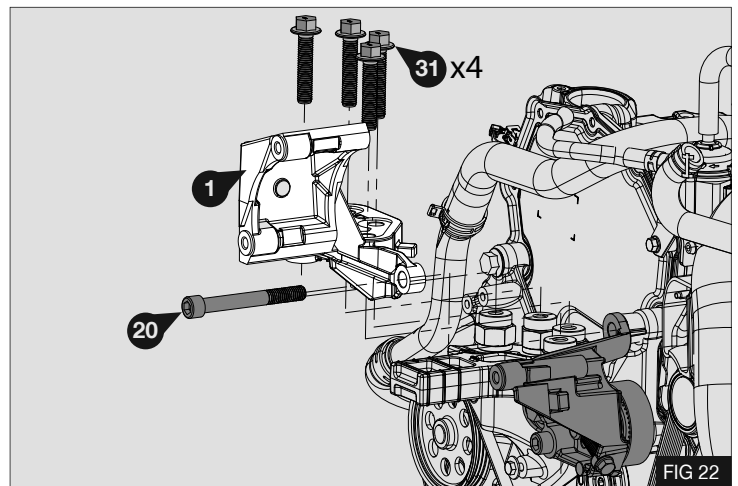

10. Fit the siren (C) to the new position using the original nut (C1) and supplied M6 Washer (32) - Figs 23/24

Torque Nut (C1) to 8Nm

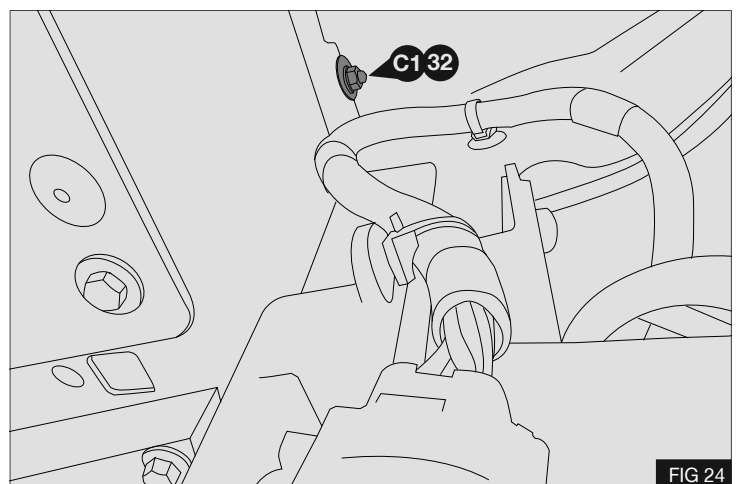
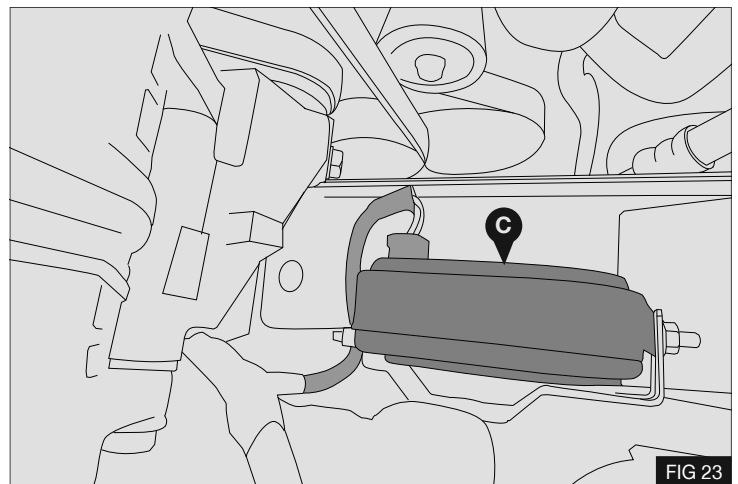

COMPRESSOR

1. Install the refrigerant compressor and secure using 6x M10 x 30 flange bolts (29) - Fig 25

Caution: Tighten the bolts at the front of the compressor first. The rear bolts locate into sliding spacers which will contact the compressor lugs when correctly torqued.

2. Torque bolts (29) to 58Nm

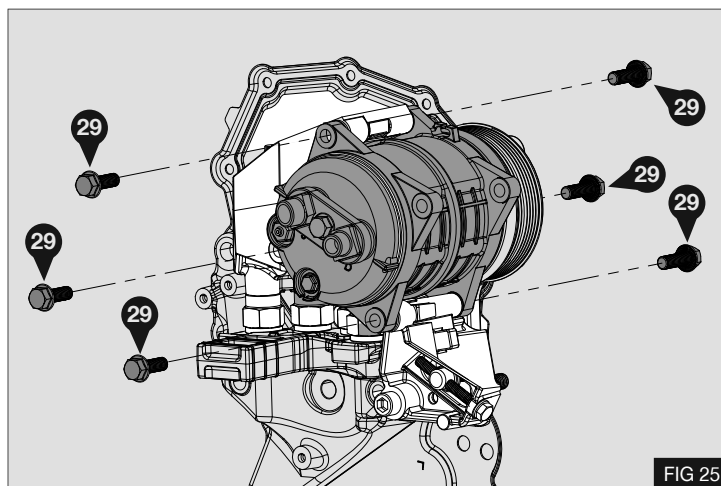

FIG 25

DRIVE BELT

1. Install the compressor drive belt (34) - Fig 26

- A Crank pulley
- B Grooved Idle pulley
- C Compressor Pulley
- D Tensioner pulley

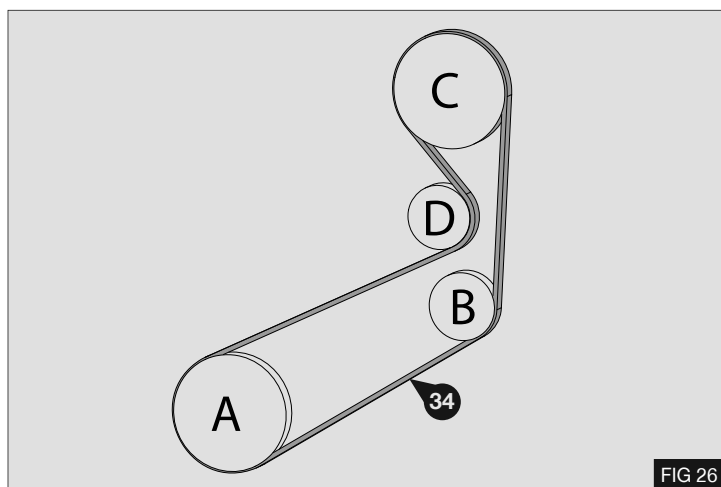

FIG 26

2. Position the belt in compressor front grooves. - Fig 27

Tension the drive belt (34) using draw bolt (27). Once the correct tension is achieved (see table) tighten the pulley nut (15) - Fig 28

IMPORTANT: Tighten pulley nut (15)

NB: Check the belt tension when the belt is hot. It is important that the belt is allowed to cool before re-tensioning. Always re-tension new belts if the tension is less than the used belt amount.

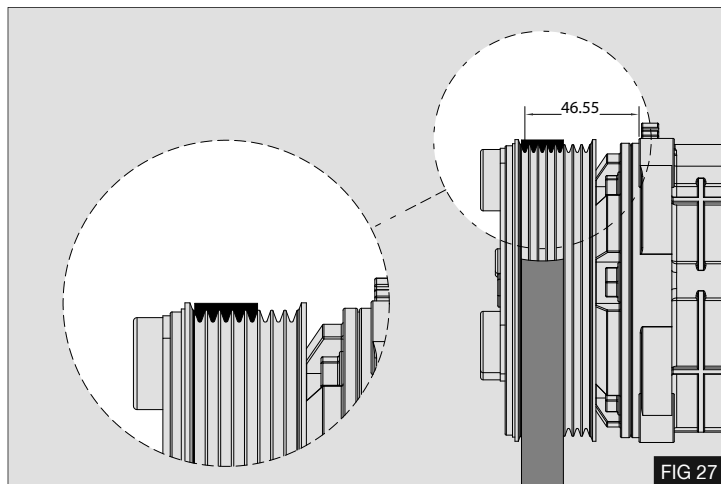

FIG 27

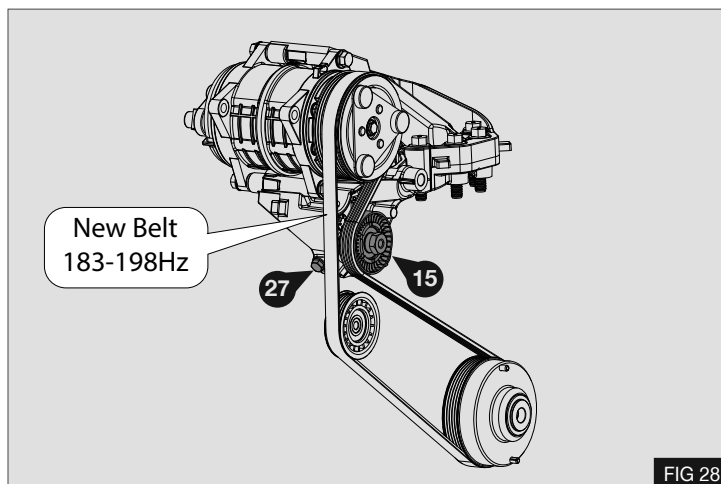

FIG 28

BELT TENSION TABLE

Belt	Belt Age	Belt Tension Using Belt Tension Gauge	Frequency. at span indicated
5PK	New Belt	60 - 70 kg	183-198Hz
5PK	Used Belt	45 - 50 kg	159-177Hz

PULLEY COVER

1. Modify the original pulley guard **D** as shown in figs 29/30

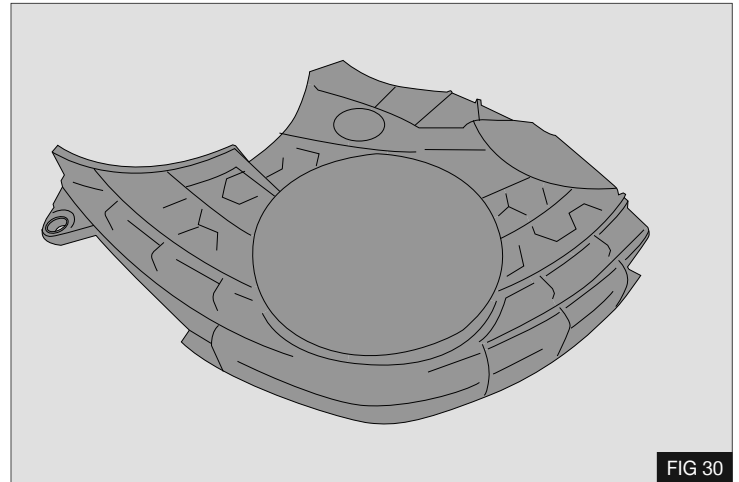
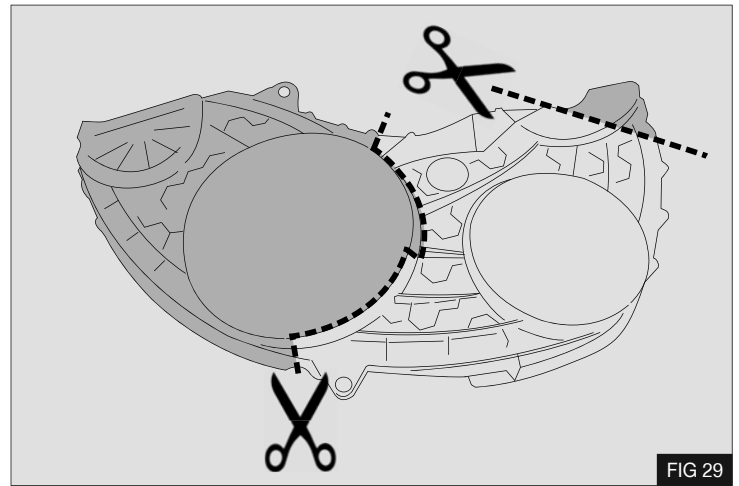

2. Fit the modified pulley guard **D** using the original fasteners where appropriate. - Fig 31

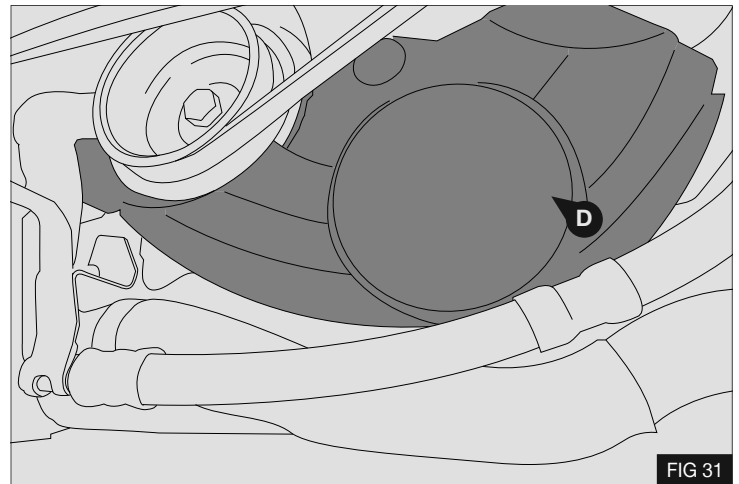

3. Fit the pulley guard support plate **36** to original threaded hole on the PAS hose support with the original fastener.
4. Position the plate **36** as shown. Drill 2x 4mm diameter holes, and secure using the rivets **33** - Fig 32

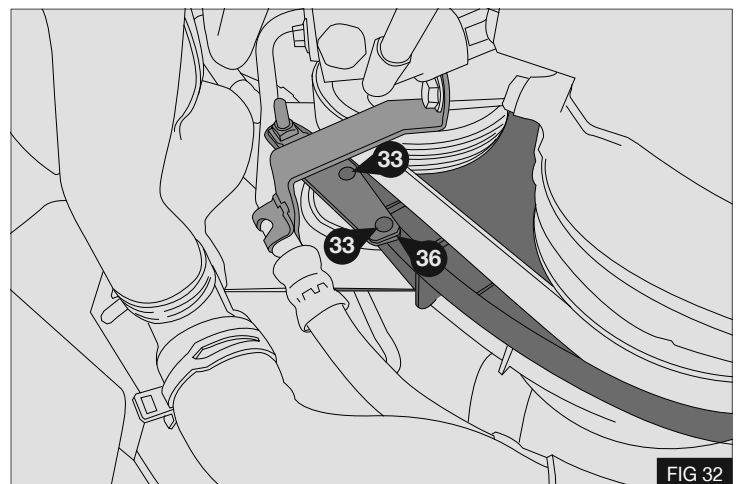

WASHER BOTTLE FILLER

1. Remove and discard the section indicated from the washer bottle filler neck (W) - Fig 33

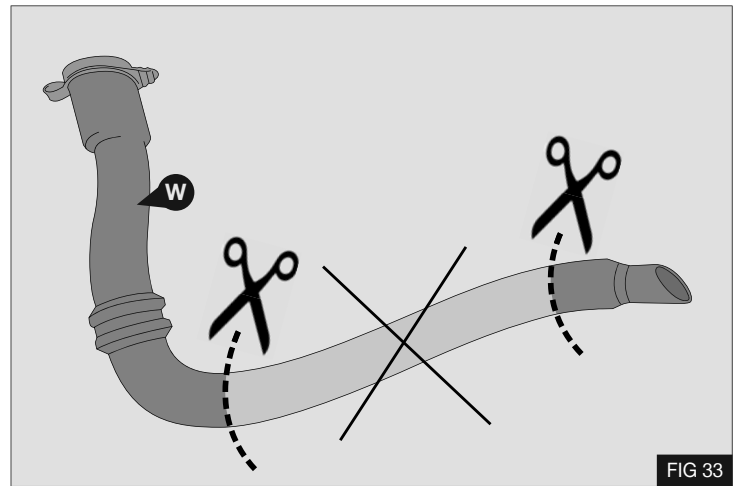

FIG 33

2. Assemble the spiral hose (42) onto the sections of the washer filler neck. Secure with Hose clamps (35) - Fig 34

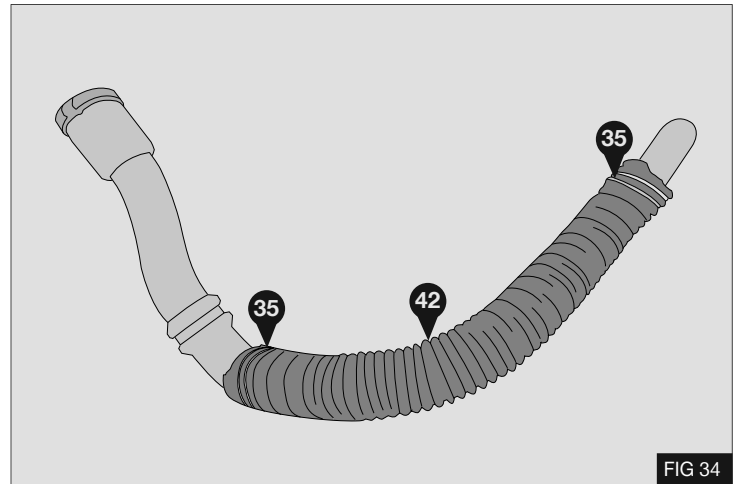

FIG 34

3. Fit the modified filler section (W) into its original support and reservoir. Secure hose (42) to the wiring harness using cable ties (41) to obtain clearance to the compressor and mountings. - Fig 35

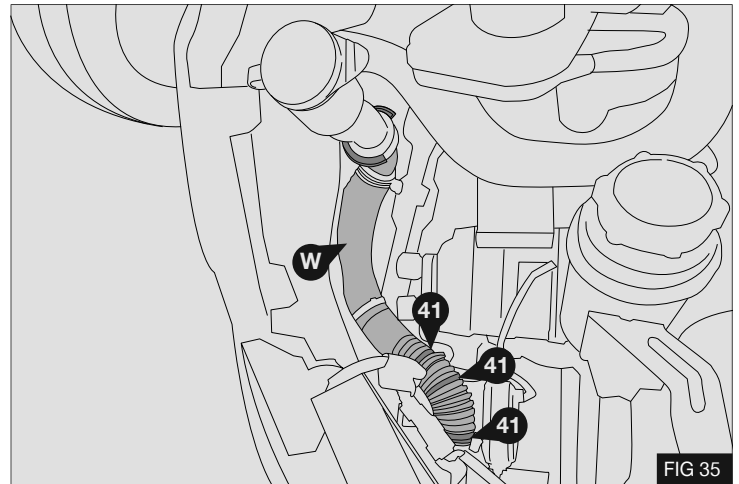

FIG 35

HOSES

1. Connect the hoses to the compressor with 90 degree fittings, Use the split tubing (39) and (40) route as shown and secure using cable ties (41) - Fig 36

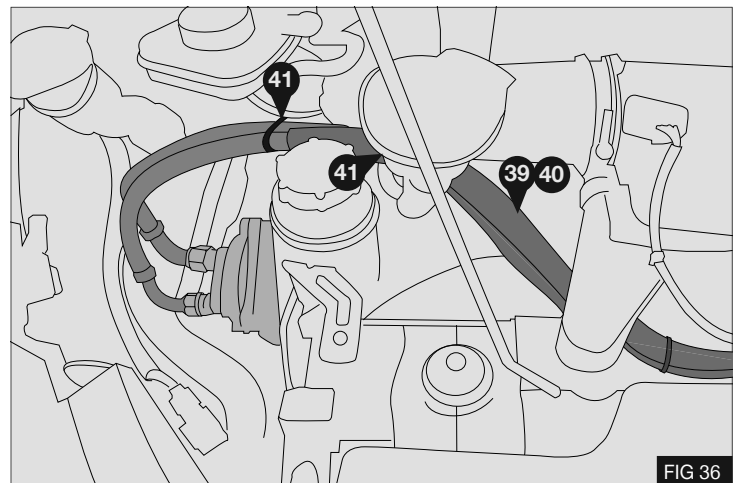

FIG 36

POST INSTALLATION

1. Before starting the engine check all the installed parts and ensure that the belt is installed correctly. Run the unit for at least ten minutes, then check the whole mounting assembly and previously removed parts. Attach the supplied warning label on to a suitable location.
2. After running the vehicle, check the belt tension and adjust as necessary. See table page 14.

(EN)

Techni focuses on constant upgrading of its products. The Manufacturer reserves the right to modify the models and components described in the present publication at any time for technical or commercial reasons and without prior notice. For further information, contact Techni technical services.

(DE)

Techni ist stets bestrebt die eigenen Produkte zu verbessern. Die Herstellerfirma behält sich das Recht vor, aus technischen oder Verkaufsgründen, zu jeder Zeit und ohne vorherige Ankündigung, Abänderungen an den Modellen und den in dieser Veröffentlichung beschriebenen Einbauteile vorzunehmen. Für weitere Informationen bitten wir Sie, sich an unseren Techni Kundendienst zu wenden.

(FR)

Techni vise à une amélioration constante des ces produits. La maison se réserve le droit d'apporter, à tout moment et sans préavis, des modifications aux modèles et aux composants décrits dans cette publication pour des raisons d'ordre technique ou commerciale. Pour d'ultérieures informations s'adresser au service d'assistance Techni.

(IT)

Techni mira ad un costante miglioramento dei propri prodotti. La Casa si riserva il diritto di apportare in qualunque momento e senza preavviso modifiche ai modelli e ai componenti descritti in questa pubblicazione per ragioni di natura tecnica o commerciale. Per ulteriori informazioni rivolgersi al servizio assistenza Techni.

(ES)

Techni aspira a un constante mejoramiento de su producción. La Fábrica se reserva el derecho de aportar en cualquier momento y sin preaviso modificaciones a los modelos y los componentes descritos en esta publicación por razones técnicas o comerciales. Para ulteriores informaciones dirigirse al servicio asistencia Techni.

VENDITA E SERVIZIO
VENTE ET SERVICE

SALES AND SERVICE
VERKAUF UND SERVICE



Sundorne Trade Park, Henley Way,
Shrewsbury, United Kingdom, SY1 4NS
Telephone (+44) (0) 1743 443176
Fax (+44) (0) 1743 443113
Email: sales@techni.co.uk